

Display Devices, Inc.
Rear Opening Outdoor Projector Enclosure [PJE-1530]

Air-conditioned enclosure with remote control and monitoring capabilities.

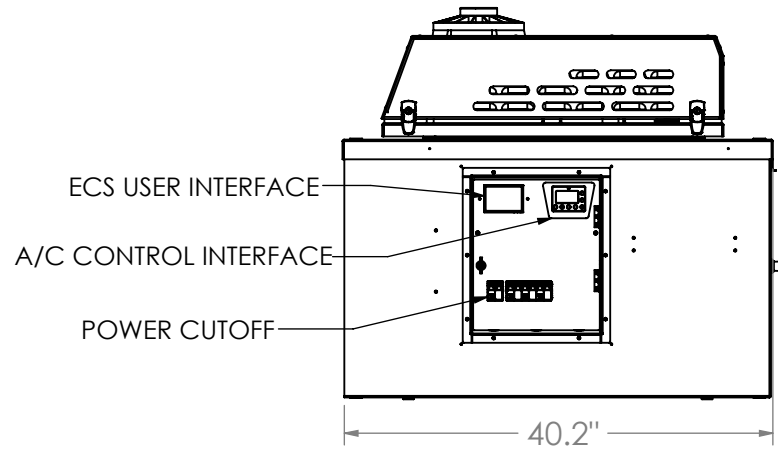
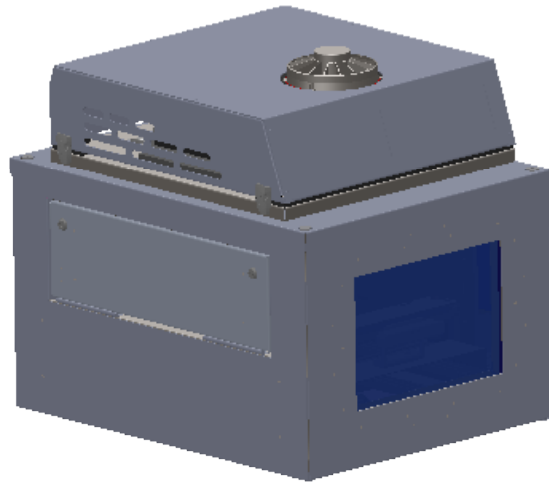
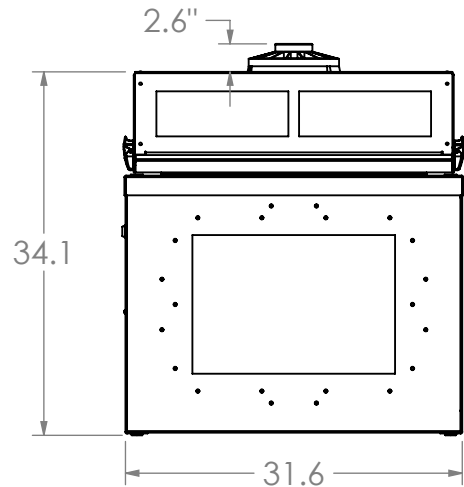
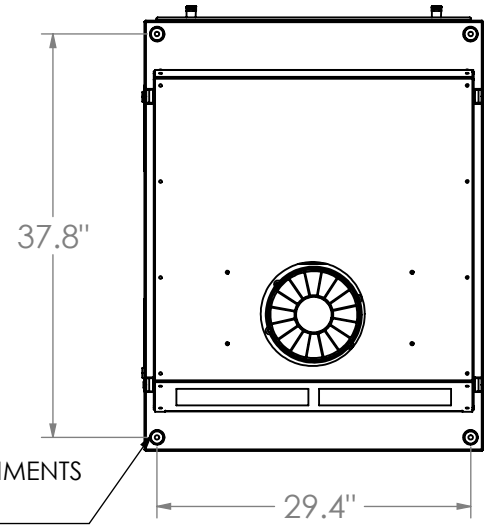
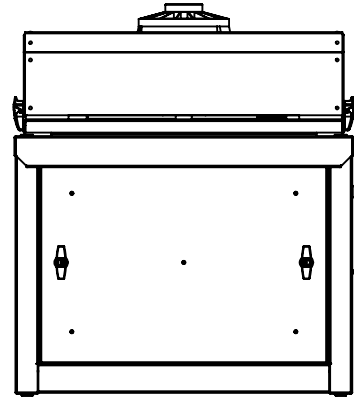
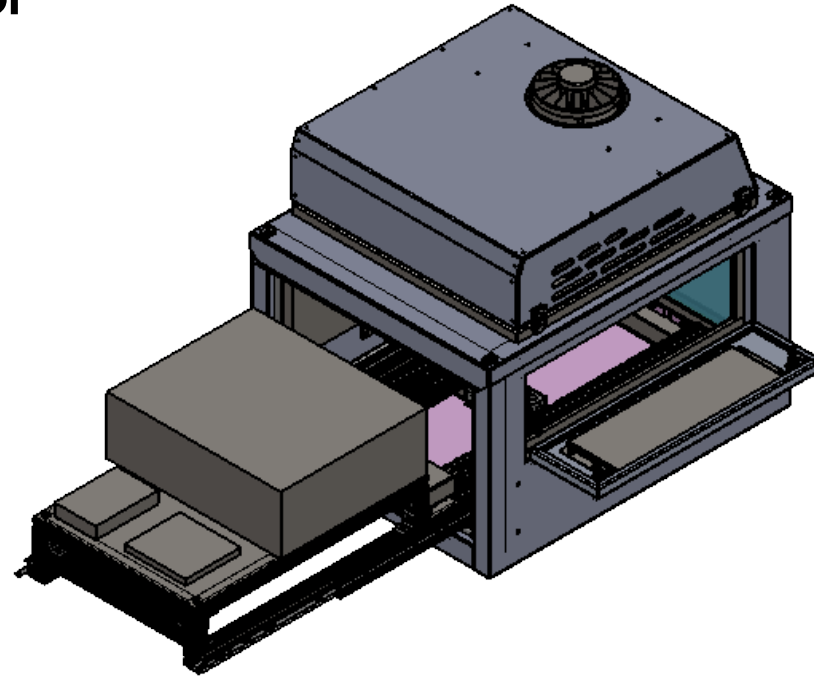

STANDARD SPECIFICATIONS

Model	DDK65DS	
Mechanical	Outside Dimensions [in]	40.2 x 31.6 x 34.1
Specs	Weight (w/o Proj.) [lb]	250
	Cooling System	8.5kBTU A/C
	Door Lock	KEYED
	Orientation	Landscape
Power	Incoming Power Voltage/Frequency	120-208/240 60Hz
	Power Draw PJE (W)	2841
Environment	Storage Temperature (°F)	15 - 105
	Storage Humidity (%RH)	10 - 95
	Operation Temperature (°F)	32-105
	Operation Humidity (%RH)	10 - 95
	Ingress Rating	IP55
	Wind Load Rating (mph)	195 (max.)

DISPLAY DEVICES
Design • Engineering • Manufacturing

21075 WESTGATE RD.
 GOLDEN, CO 80403
 PHONE: 303.412.0399

8 7 6 5 4 3 2 1

D
C
B
A

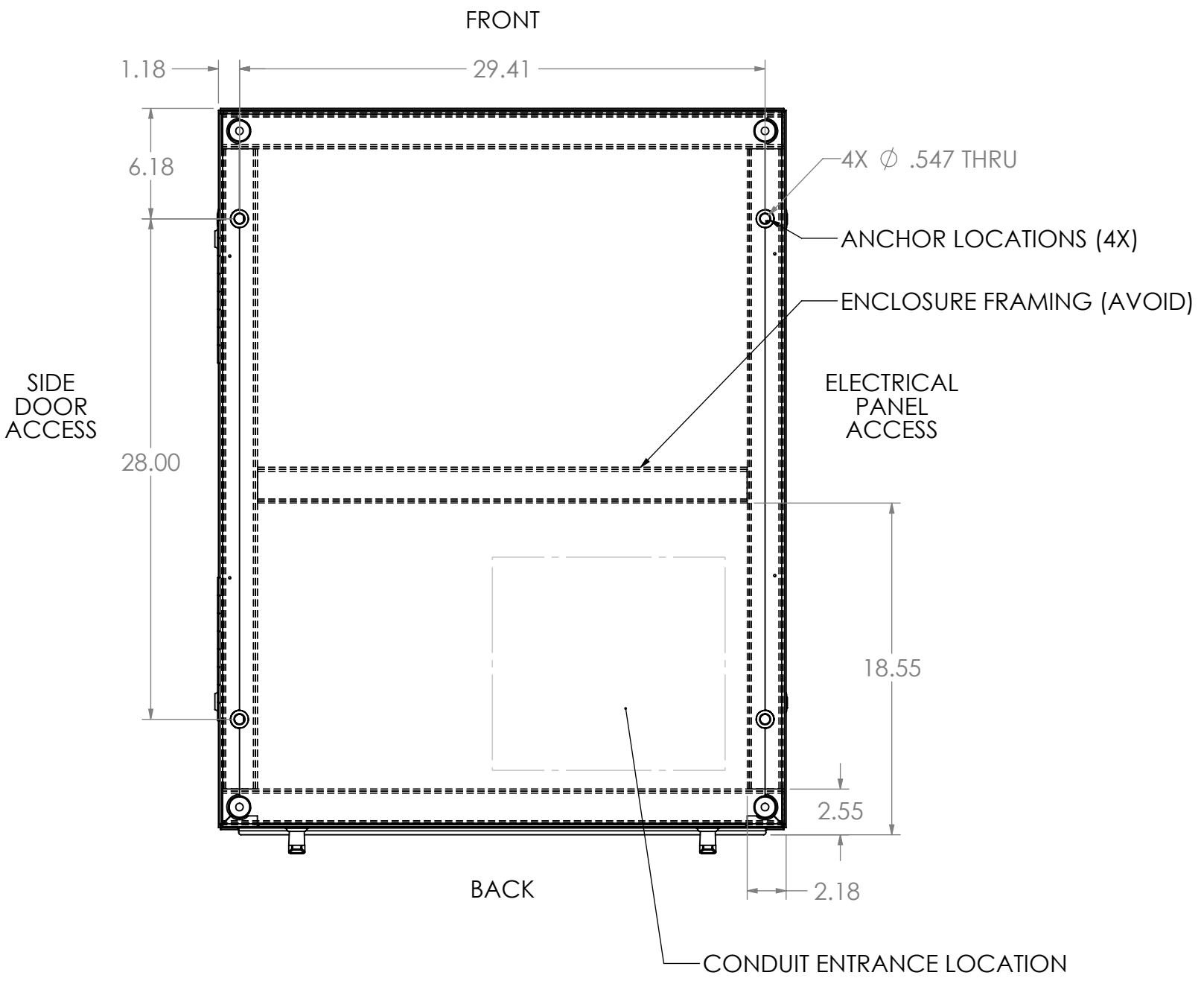

SIZE	DWG. NO.	REV
B	8105-06700	A
SCALE: 1:8		SHEET 2 OF 2

8 7 6 5 4 3 2 1