

2050S Outdoor Projector Enclosure

DISPLAY DEVICES

Design • Engineering • Manufacturing

The versatile environmental enclosure for projectors ranging from 20k-50k lumens

- *Climate controlled for reliable operation from 0°F-105°F*
- *Custom sizes and mounting options available*
- *Wind load rating of 195mph*

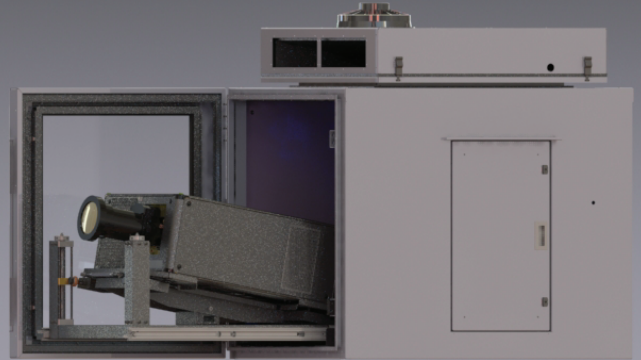
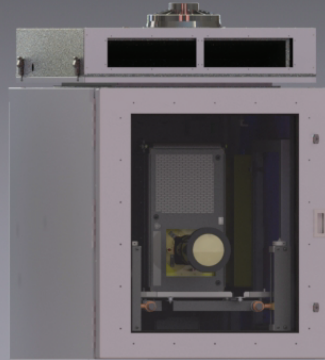
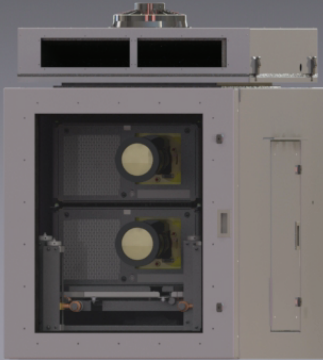
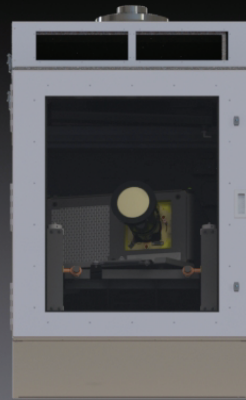

Display Devices, Inc. Standard Outdoor Projector Enclosure [PJE-2050S]

Air-conditioned, climate-controlled enclosure with remote control and monitoring capabilities.

- *Custom sizes and mounting options available*
- *Installation services*

STANDARD SPECIFICATIONS

Model	DDK65DS	
Mechanical	Outside Dimensions [in]	58.6 x 41.6 x 59.2
	inside Dimensions [in]	50.3 x 35.5 x 39
Specs	Weight (w/o Proj.) [lb]	450
	Cooling System	24kBTU Air Conditioner
	Door Lock	Hex Key
	Orientation Adjustment	Portrait/Landscape ±10° Tilt and Pan
Power	Power Supply Rated Voltage/Frequency	Multiple 100-220VAC/50-60Hz
	Power Draw (W)	2250
	Environment	
Storage	Temperature (°F)	15 - 105
	Humidity (%RH)	10 - 95
Operation	Temperature (°F) w/ Heater	0 - 105
	w/o Heater	32 - 105
	Humidity (%RH)	10 - 95
	Ingress Rating	IP55
Wind Load Rating (mph)	195 (max.)	

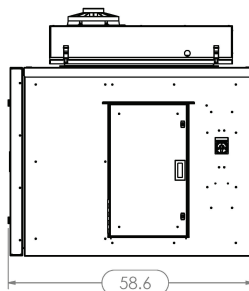
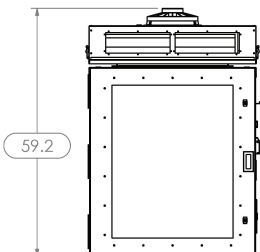
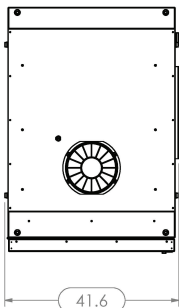
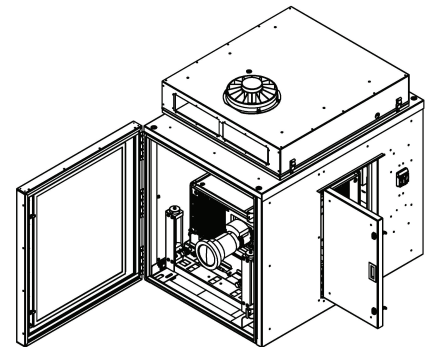

VANDAL RESISTANT



WEATHER PROOF



HURRICANE RATED

DISPLAY DEVICES

Design • Engineering • Manufacturing

21075 WESTGATE RD.
GOLDEN, CO 80403
PHONE: 303.412.0399